

1. T7 skal monteres EFTER suppleringsvarme. Evt. i kanal.
2. Komponenter med stiptet forbindelse er tilbehør
3. Eksterne komponenter er ikke Nilan leverance
4. Optionsprint er tilbehør til CTS602
5. Ⓐ – Ⓔ Tilslutning af suppleringsvarme

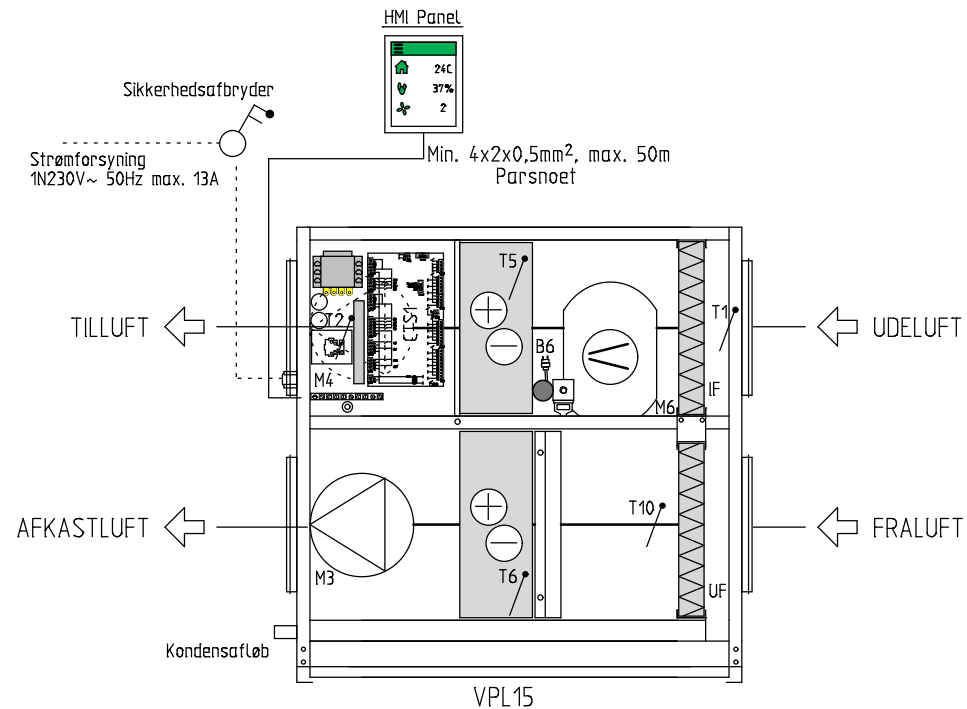

NILAN A/S
 Nilanvej 2
 DK-8722 Hedensted
 Tlf. +4576752500 <http://www.nilan.dk>
 Fax +4576752525 Email: nilan@nilan.dk

VPL15 Køl
 CTS602 Styling / HMI-panel
 Varenr. 71363x23

Principdiagram

Ordrenr.

Revision 1.02

Initialer MD

Dato 22/11-2021

Nationalitet DK / N / S / SF

Side 1

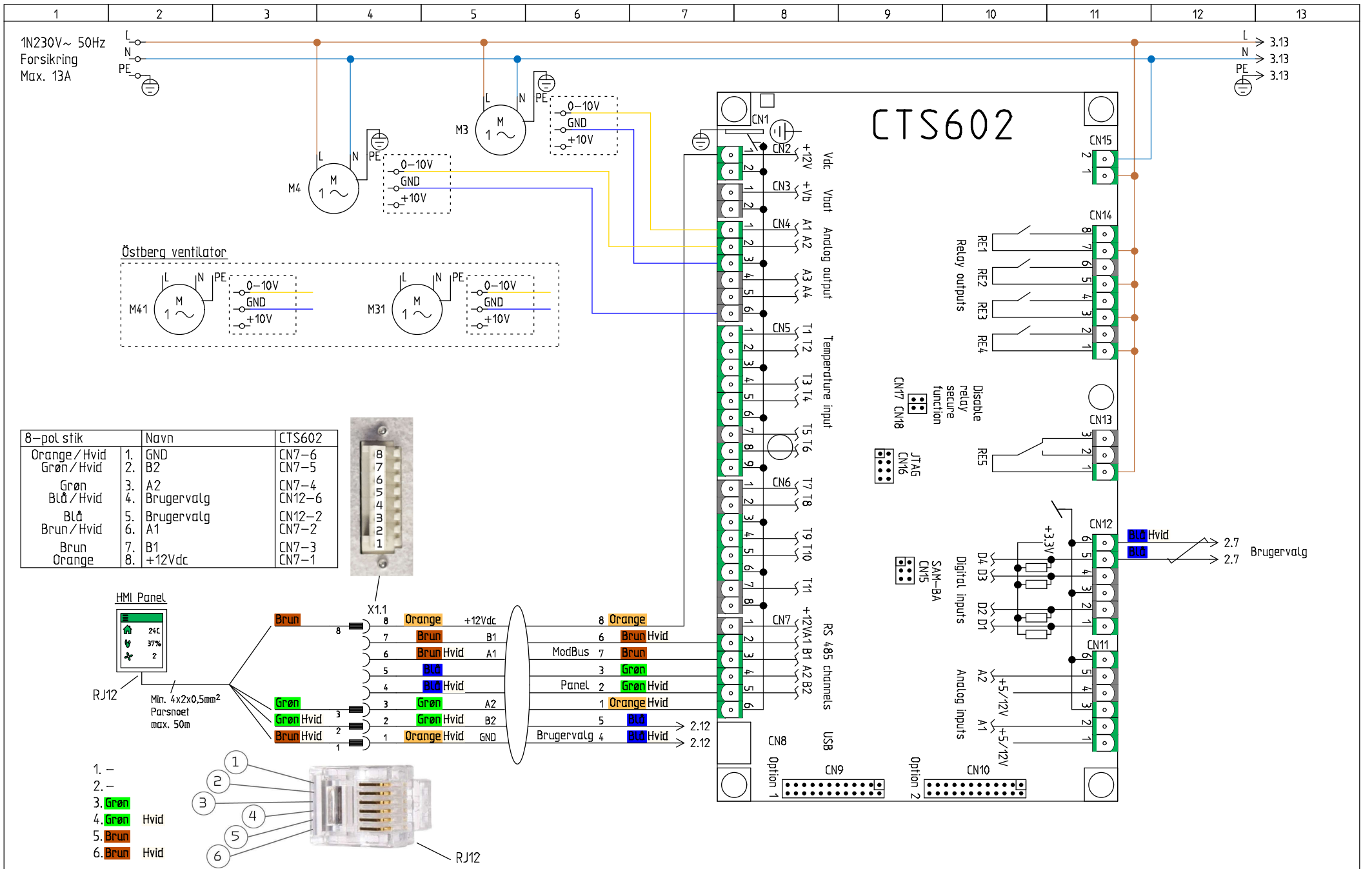

8-pol stik	Navn	CTS602
Orange / Hvid	1. GND	CN7-6
Grøn / Hvid	2. B2	CN7-5
Grøn	3. A2	CN7-4
Blå / Hvid	4. Brugervalg	CN12-6
Blå	5. Brugervalg	CN12-2
Brun / Hvid	6. A1	CN7-2
Brun	7. B1	CN7-3
Orange	8. +12Vdc	CN7-1

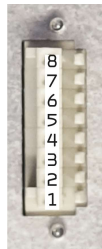

HMI Panel

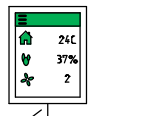

RJ12
Min. 4x2x0,5mm²
Parsnoet
max. 50m

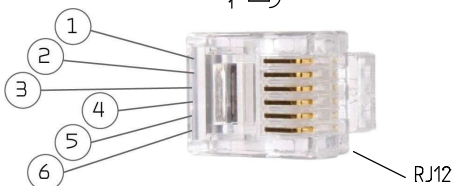

NILAN A/S
 Nilanvej 2
 DK-8722 Hedensted
 Tlf. +4576752500
 Fax +4576752525
<http://www.nilan.dk>
 Email : nilan@nilan.dk

VPL15 Køl
 CTS602 Styling / HMI-panel
 Varenr. 71363x23

CTS602 Styling

Ordrenr.	Revision	Initialer
	1.02	MD
Dato	Nationalitet	Side
22/11-2021	DK / N / S / SF	2

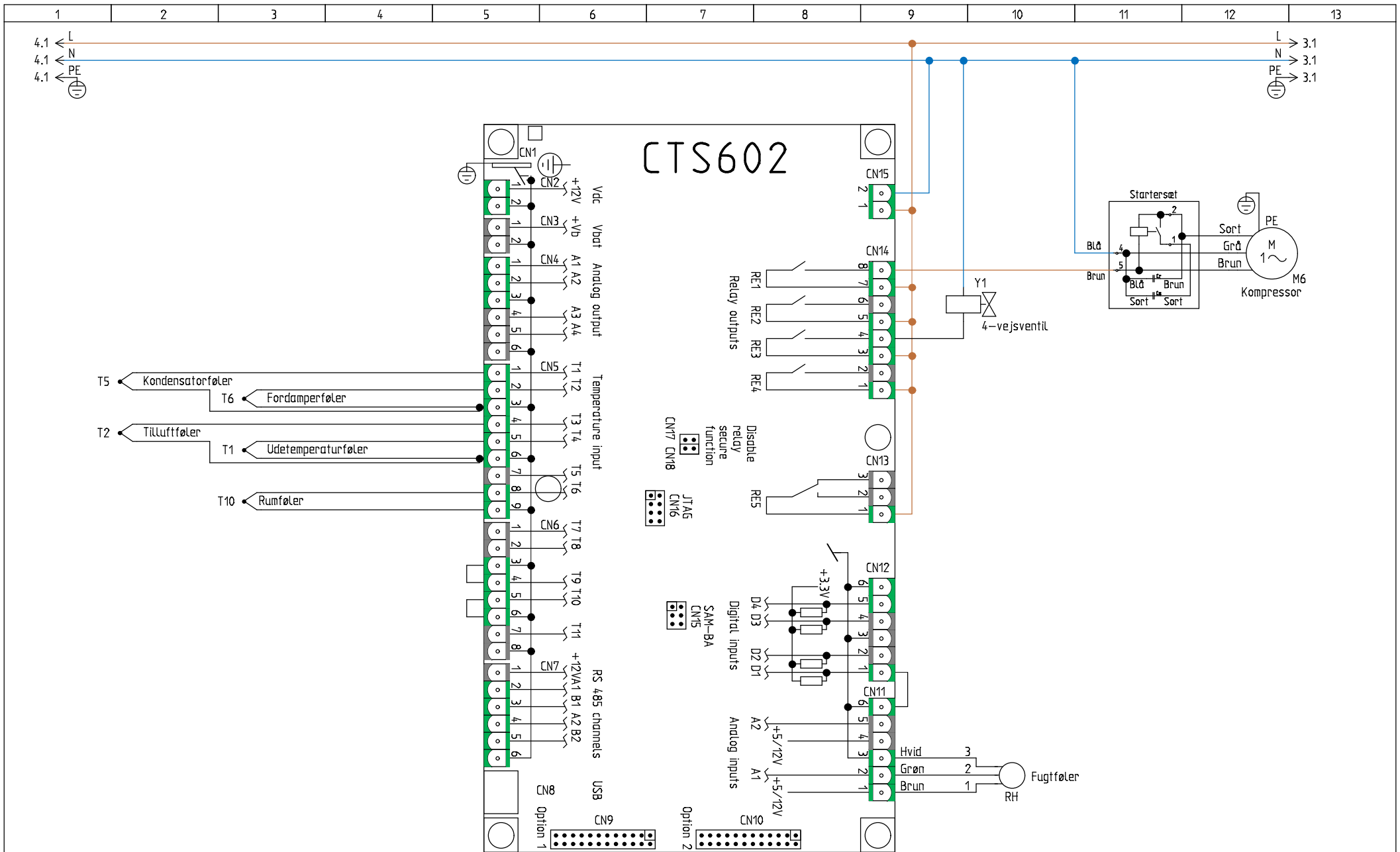

NILAN A/S
 Nilanvej 2
 DK-8722 Hedensted
 Tlf. +4576752500 <http://www.nilan.dk>
 Fax +4576752525 Email: nilan@nilan.dk

VPL15 Køl
 CTS602 Styring / HMI-panel
 Varenr. 71363x23

CTS602 Styring

Ordrenr.	Revision	Initialer
	1.02	MD
Dato	Nationalitet	Side
22/11-2021	DK / N / S / SF	3

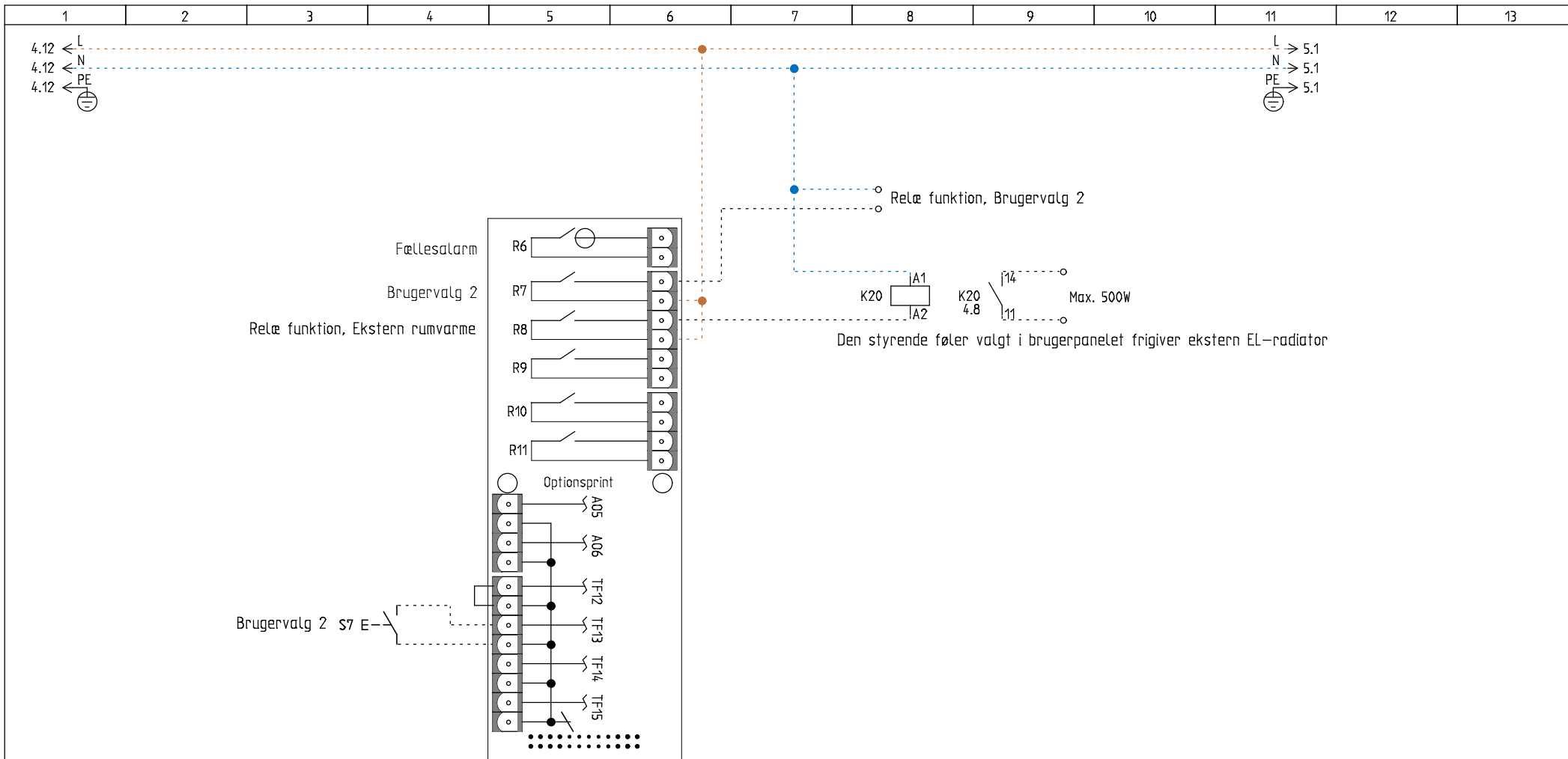

NILAN A/S
 Nilanvej 2
 DK-8722 Hedensted
 Tlf. +4576752500 <http://www.nilan.dk>
 Fax +4576752525 Email : nilan@nilan.dk

VPL15 Køl
 CTS602 Styling / HMI-panel
 Varenr. 71363x23

Optionsprint

Ordrenr.

Revision 1.02

Initialer MD

Dato 22/11-2021

Nationalitet DK / N / S / SF

Side 4

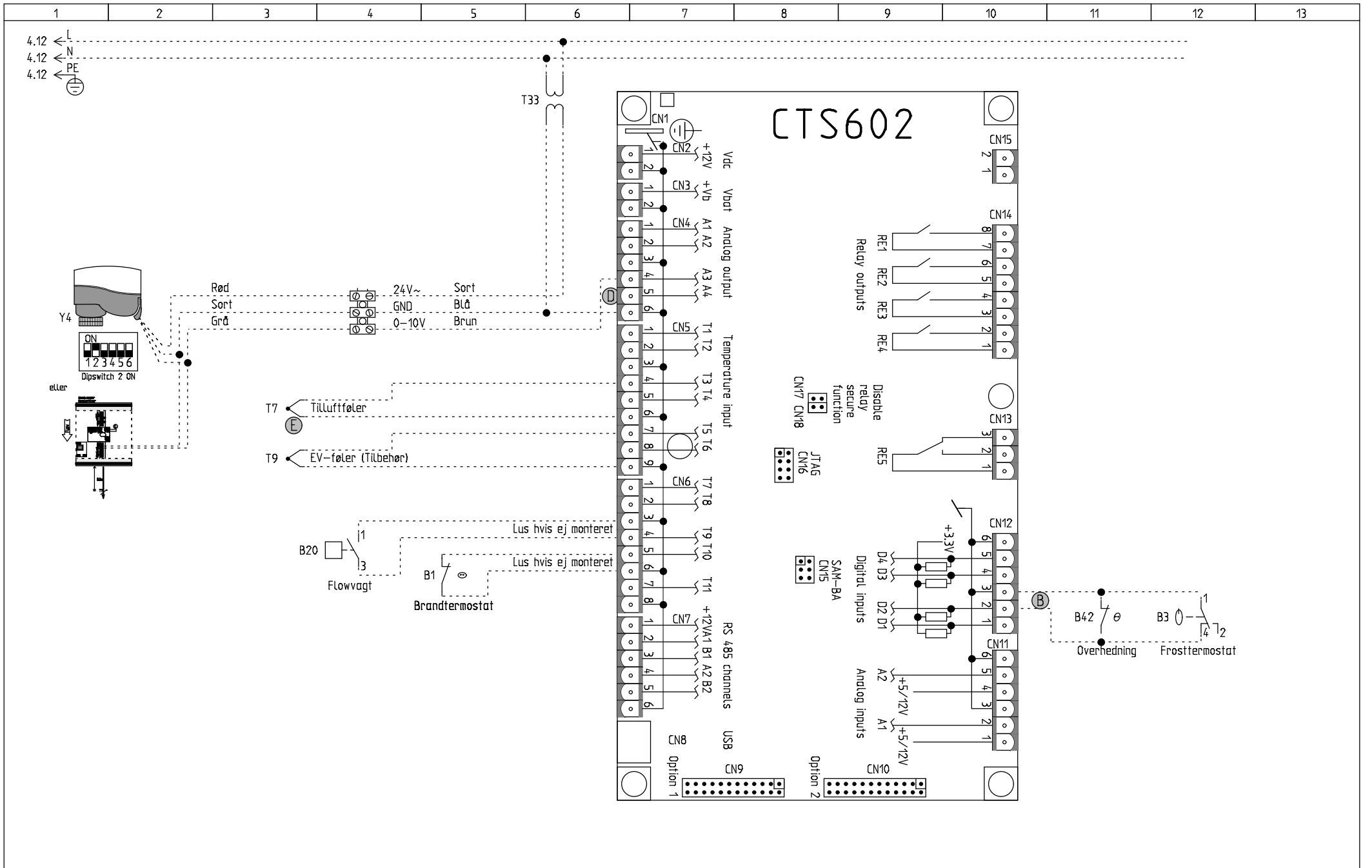

Produktliste

Produkt	Type	Beskrivelse	Dokumenttype	Side	Strømvej
B1	EGO 55.33519.020 70–5°C, #15441	Brandtermostat Tilluft (Tilbehør)	Kredsskema	5	5
B3	55.13309.090, #15662	Frosttermostat	Kredsskema	5	12
B20	Huba 20–300Pa, #3635	Flowvagt (Tilbehør)	Kredsskema	5	4
B42	EGO 55.13019.180 60°C, #1564	Begrænsertermostat EL-supplering (Tilbehør)	Kredsskema	5	11
Cr	10µF, #1015–2	Driftskondensator	Kredsskema	3	12
Cs	80µF, #1015–2	Startkondensator	Kredsskema	3	12
CTS1	#239932	CTS602 Styring	Kredsskema	1	7
E1	EL-varme	Ekstern rumvarme (Ej Nilan Leverance)	Kredsskema	4	10
IF	Camfil 5061410 3GPF 360x225x50–90 (F7)	Tilluft filter	Kredsskema	1	9
K20	Telemecanique RSB1A120P7S 230V, #23466	Relæ EL–Radiator	Kredsskema	4	8
M3	EBM G3G140–AV17–48, #41003	Fraluftmotor	Kredsskema	2	5
M4	EBM G3G140–AV17–48, #41003	Tilluftmotor	Kredsskema	2	4
M6	Danfoss SC15GHH 220–240V~ 50Hz, #1015	Kompressor	Kredsskema	3	12
M31	Östberg 140 FG140/6051–08	Fraluftmotor	Kredsskema	2	5
M41	Östberg 140 FG140/6051–08	Tilluftmotor	Kredsskema	2	2
Print	#239935	Optionsprint (Tilbehør)	Kredsskema	4	5
RH	#23997 / #239971	Fugtføler	Kredsskema	3	9
S7	Kontakt	Kontakt for brugervalg 2 (Ej Nilan Leverance)	Kredsskema	4	4
T1	NTC–føler JM103C1R1, #23995	Udetemperaturføler	Kredsskema	3	3
T2	NTC–føler JM103C1R1, #23995	Tilluftføler	Kredsskema	3	2
T5	NTC–føler JM103C1R1, #23995	Kondensatorføler	Kredsskema	3	2
T6	NTC–føler JM103C1R1, #23995	Fordamperføler	Kredsskema	3	3
T7	NTC–føler JM103C1R1, #23995	Tilluftføler	Kredsskema	5	4
T9	NTC–føler JM103C1R1, #23995	EV–føler (Tilbehør)	Kredsskema	5	4
T10	NTC–føler JM103C1R1, #23995	Rumføler	Kredsskema	3	3
T33	230/24V~, #1753	Transformer (Tilbehør)	Kredsskema	5	6
UF	Camfil 5061465 3GPF 360x225x50–45 (F5)	Fraluft filter	Kredsskema	1	9
X1.1			Kredsskema	2	5
X2.1			Kredsskema	2	4
X2.1			Kredsskema	2	4



VPL15 Køl
 CTS602 Styring / HMI–panel
 Varenr. 71363x23

Projekt
 71363x23 V1–02 211122

Antal sider
 2

Dato
 22–11–2021

Land
 DK / N / S / SF

Næste side
 2

Side
 1

Produktliste

Produkt	Type	Beskrivelse	Dokumenttype	Side	Strømvej
X2.1			Kredsskema	2	4
X2.1			Kredsskema	2	4
Y1	STF-0129G, #16462 & Spole, #16490	4-vejsventil	Kredsskema	3	10
Y4	Danfoss AME140, 16341	Modulerende vandvarmeventil (Tilbehør)	Kredsskema	5	2
11201	VEAB CV16-09-1-MTXL	Kanalvarmer 900W (Tilbehør)	Kredsskema	5	2
11202	VEAB CV16-21-1MTXL	Kanalvarmer 2100 W (Tilbehør)	Kredsskema	5	1